

S440

Full GNSS Band Antenna



- ✧ Supported Systems :GPS/GLONASS/Beidou/Galileo/IRNSS/QZSS/SBAS/NAVIC;
- ✧ Frequency Range:1556~1623 and 1164~1288 MHz;
- ✧ Gain: 40 ± 2 dBi;
- ✧ Operating voltage: 3.3V~12VDC;
- ✧ Phase centre stability over a wide angular range in the vertical plane;
- ✧ Multi-star multi-frequency zero-phase centre dielectric antenna;
- ✧ High unit gain, wide directional map beam, low elevation angle still possible;
- ✧ With multipath resistant choke plate for high measurement accuracy;
- ✧ Low noise amplifier with bandpass filter.

WWW.GEMSNAV.COM

Functional features

The S440 four-system active antenna is a measurement antenna that integrates GPS, Glonass, Beidou2, Galileo and other satellite signals.

The antenna adopts multi-feed point design to ensure that the phase centre and geometric centre of the antenna coincide and improve the accuracy of measurement. The high gain of the antenna unit and the wide directional beam ensure that the antenna can still receive stars normally in some heavily obscured areas. The antenna is equipped with a multipath choke plate, which effectively reduces the influence of multipath on the measurement accuracy. Built-in low-noise amplification module, filtering the interference signal through multi-stage filter to ensure normal operation in harsh electromagnetic environment.

Electrical parameters

Frequency [MHz]	1556~1623/1164~1288
Input impedance	50 Ω
Gain [dBi]	40±2(With LNA gain)
Polarisation method	Right-handed circular polarization (RHCP)
Shaft ratio [dB]	≤3
Horizontal coverage angle	360°
Maximum gain	5.5dBi
Output standing wave (VSWR)	≤2.0

Low noise amplifier indicator:

Frequency range (MHz)	1556~1623/1164~1288
Gain (dB)	40±2
In-band flatness (dB)	±2 dB
Noise factor(dB)	≤2 dB
Output standing wave(VSWR)	≤2.0
Input standing wave (VSWR)	≤2.0
Voltage	DC 3.3-12V
Current	DC ≤45mA

Mechanical properties :

Size [mm]	Ø174×63
Connection head	TNC-C-K
Operating temperature [°C]	-40~+85
Storage temperature [°C]	-55~+85
Humidity	95% non-condensing
Waterproof rating	IP67

Overall Performance

Test Environment

- KEYSIGHT VNA Network Analyzer E5063A 100 kHz - 8.5 GHz
- RayZone®2800 Chamber 5G (FR1) SISO/MIMO, 400 MHz - 8.0 GHz

Return Loss

GPS L2/L5, BDS B2/ B3, GLONASS L2, Galileo E5a/E5b/E6

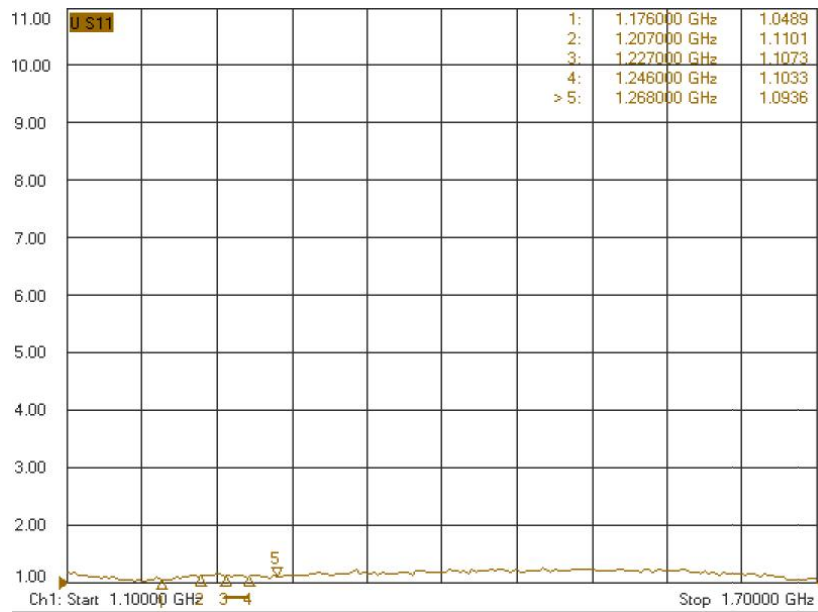

Frequency (MHz)	1176	1207	1227	1246	1268
Return Loss	1.04	1.11	1.1	1.1	1.1

GPS L1, BDS B1, GLONASS L1, Galileo E1, L-band

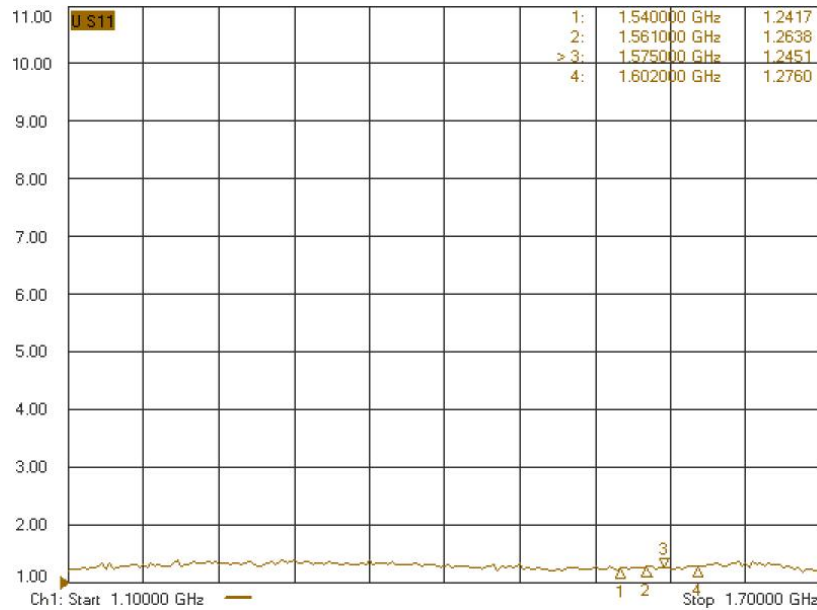

Frequency (MHz)	1540	1561	1575	1602
Return Loss	1.24	1.26	1.25	1.28

Efficiency

GPS L2/L5、BDS B2/ B3、GLONASS L2、Galileo E5a/E5b/E6

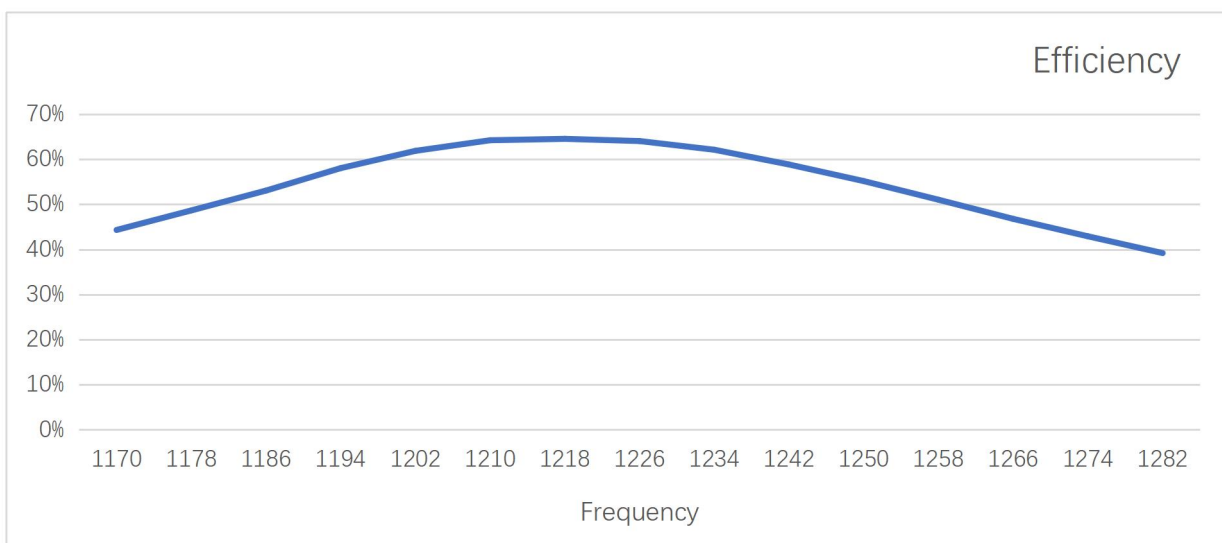

Frequency (MHz)	1176	1207	1227	1246	1268
Efficiency (%)	48	62	64	57	47

GPS L1, BDS B1, GLONASS L1, Galileo E1, L-band

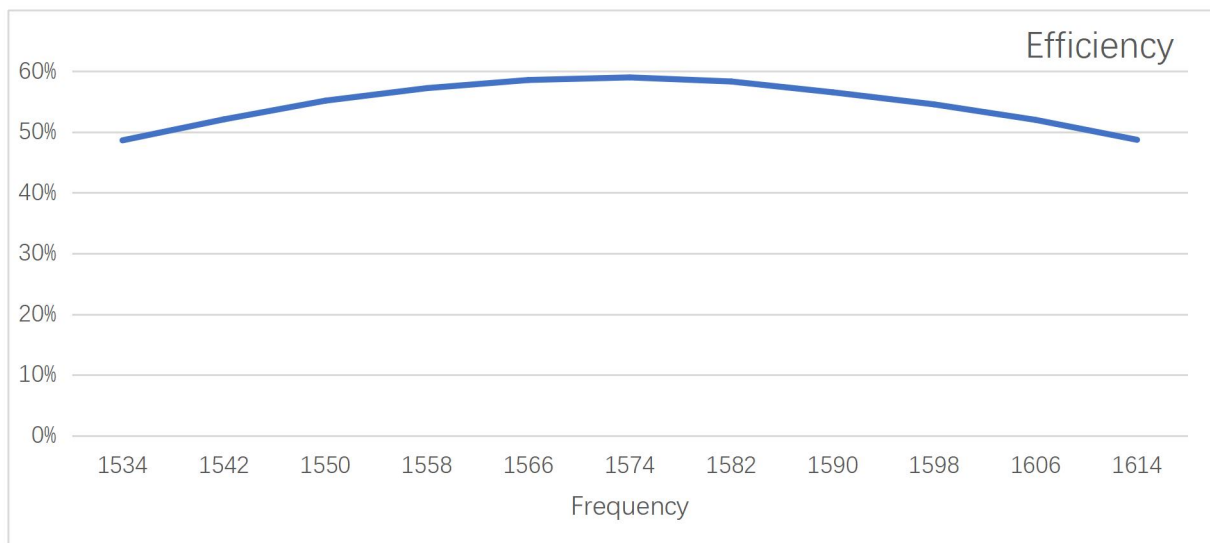

Frequency (MHz)	1540	1561	1575	1602
Efficiency (%)	52	58	59	53

Gain

GPS L2/L5, BDS B2/ B3, GLONASS L2, Galileo E5a/E5b/E6

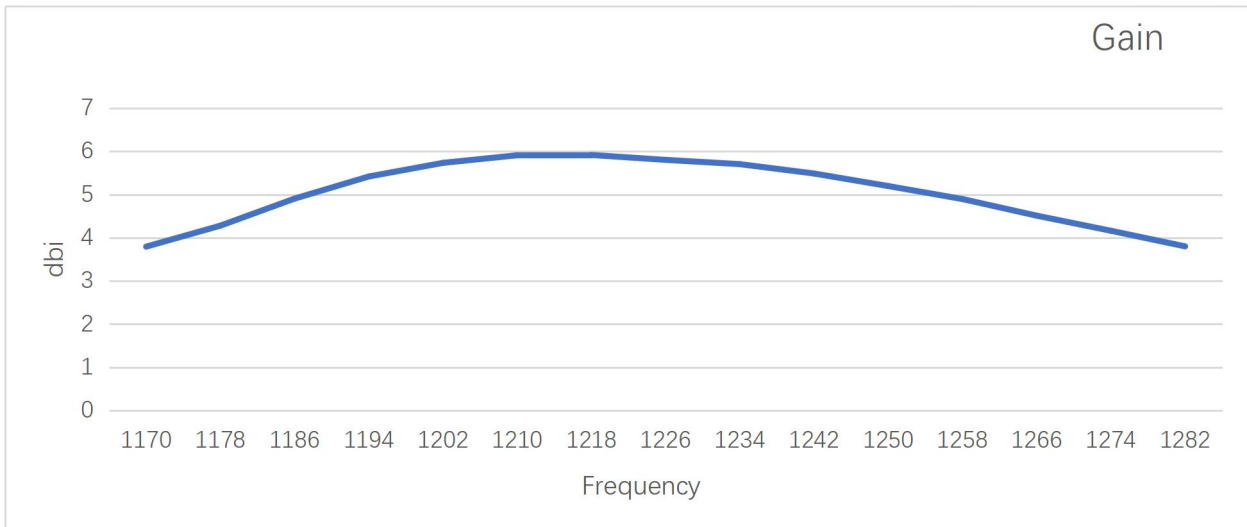

Frequency (MHz)	1176	1207	1227	1246	1268
gain (dBi)	4.1	5.8	5.8	5.3	4.3

GPS L1, BDS B1, GLONASS L1, Galileo E1, L-band

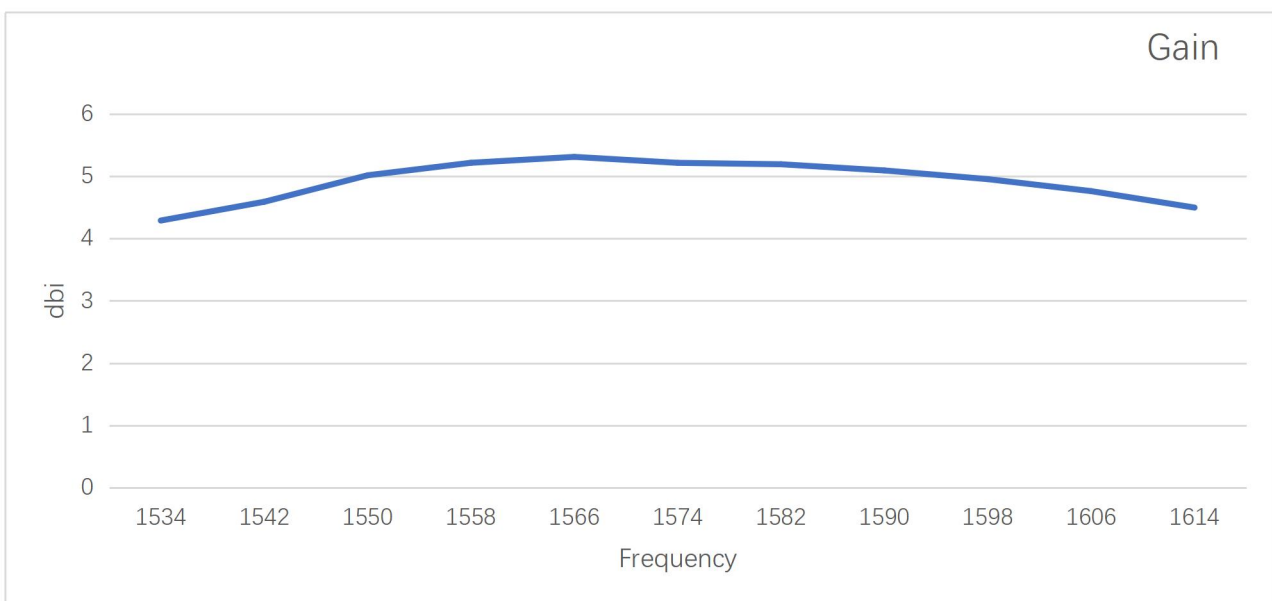

Frequency (MHz)	1540	1561	1575	1602
gain (dbi)	4.6	5.3	5.5	4.9

LNA Gain

GPS L2/L5, BDS B2/ B3, GLONASS L2, Galileo E5a/E5b/E6

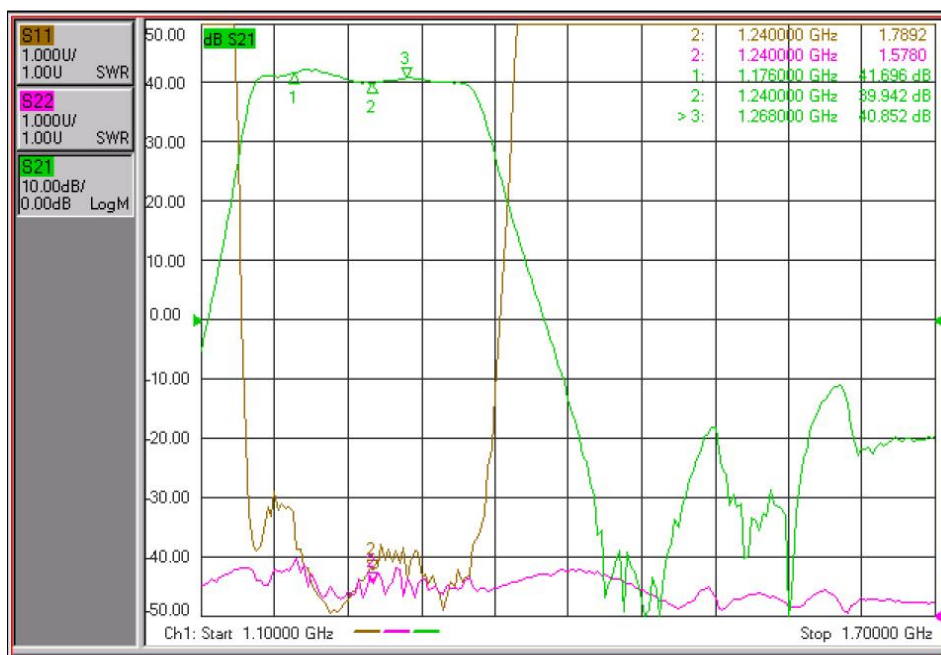

Frequency (MHz)	1176	1240	1268
gain (db)	41.5	40	40.8

GPS L1, BDS B1, GLONASS L1, Galileo E1, L-band

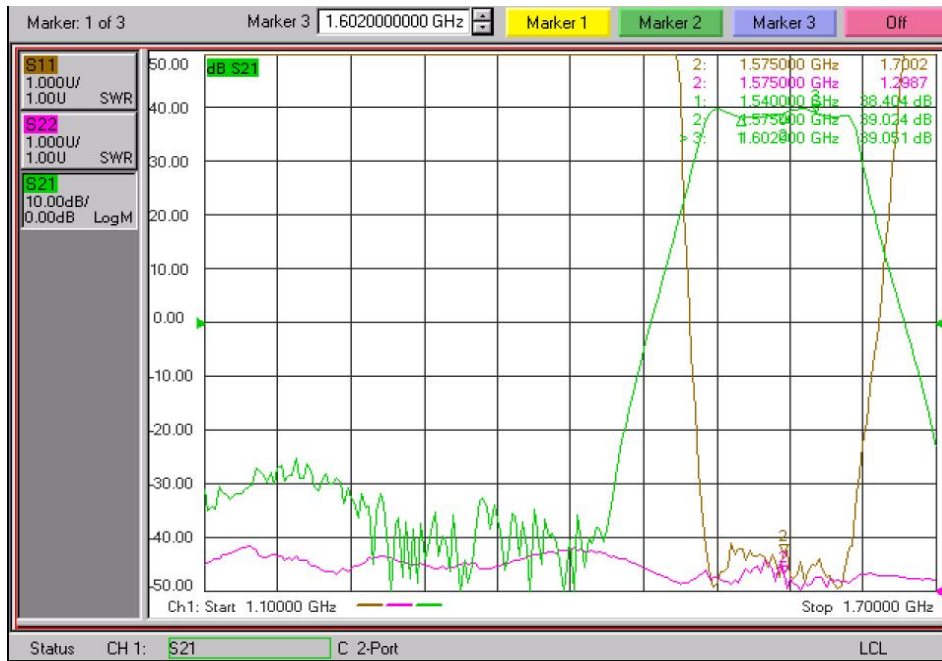

Frequency (MHz)	1540	1575	1602
gain (db)	38.5	39	39

Radiation Patterns

GPS L2/L5, BDS B2/ B3, GLONASS L2, Galileo E5a/E5b/E6

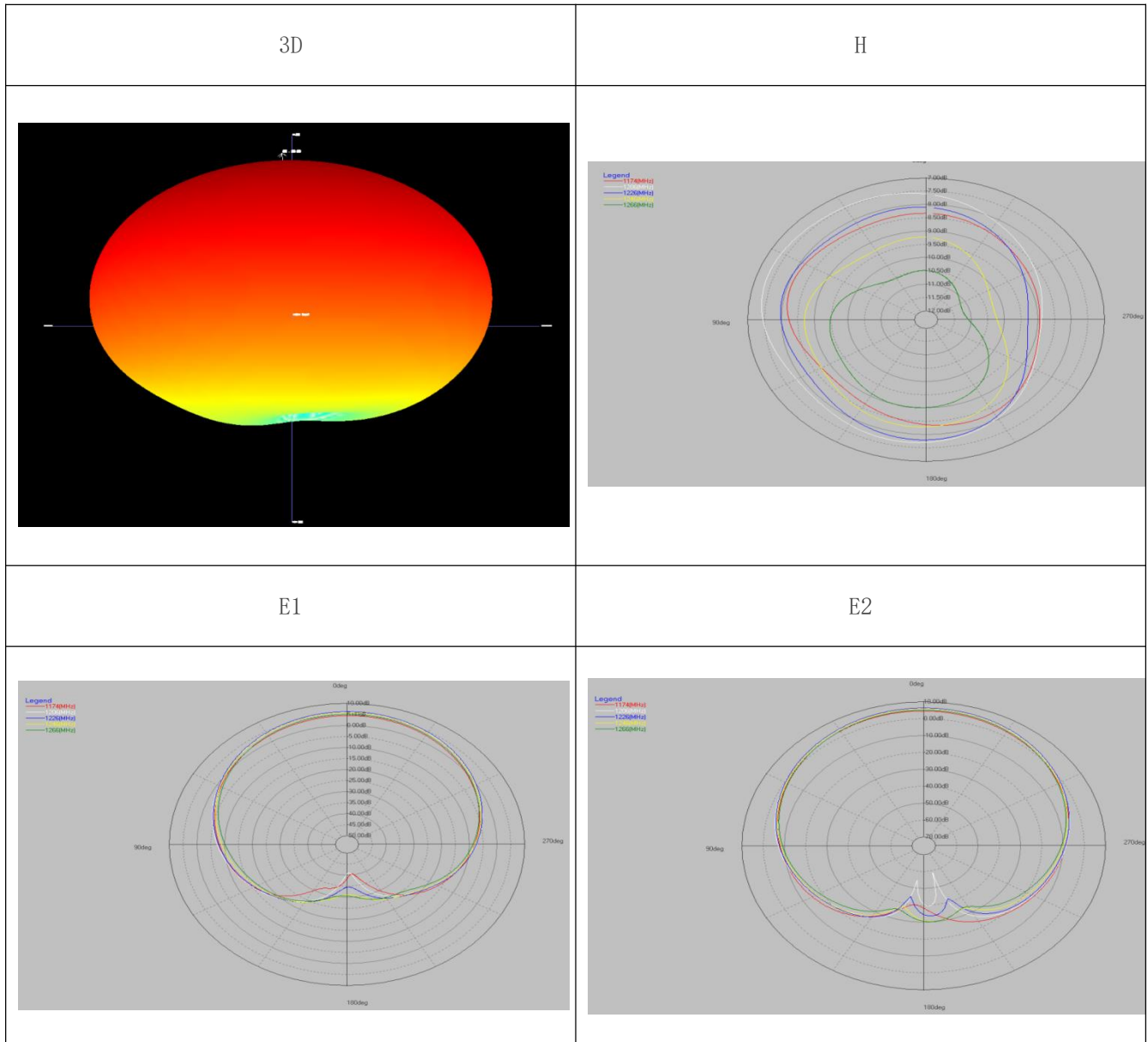

GPS L1, BDS B1, GLONASS L1, Galileo E1, L-band

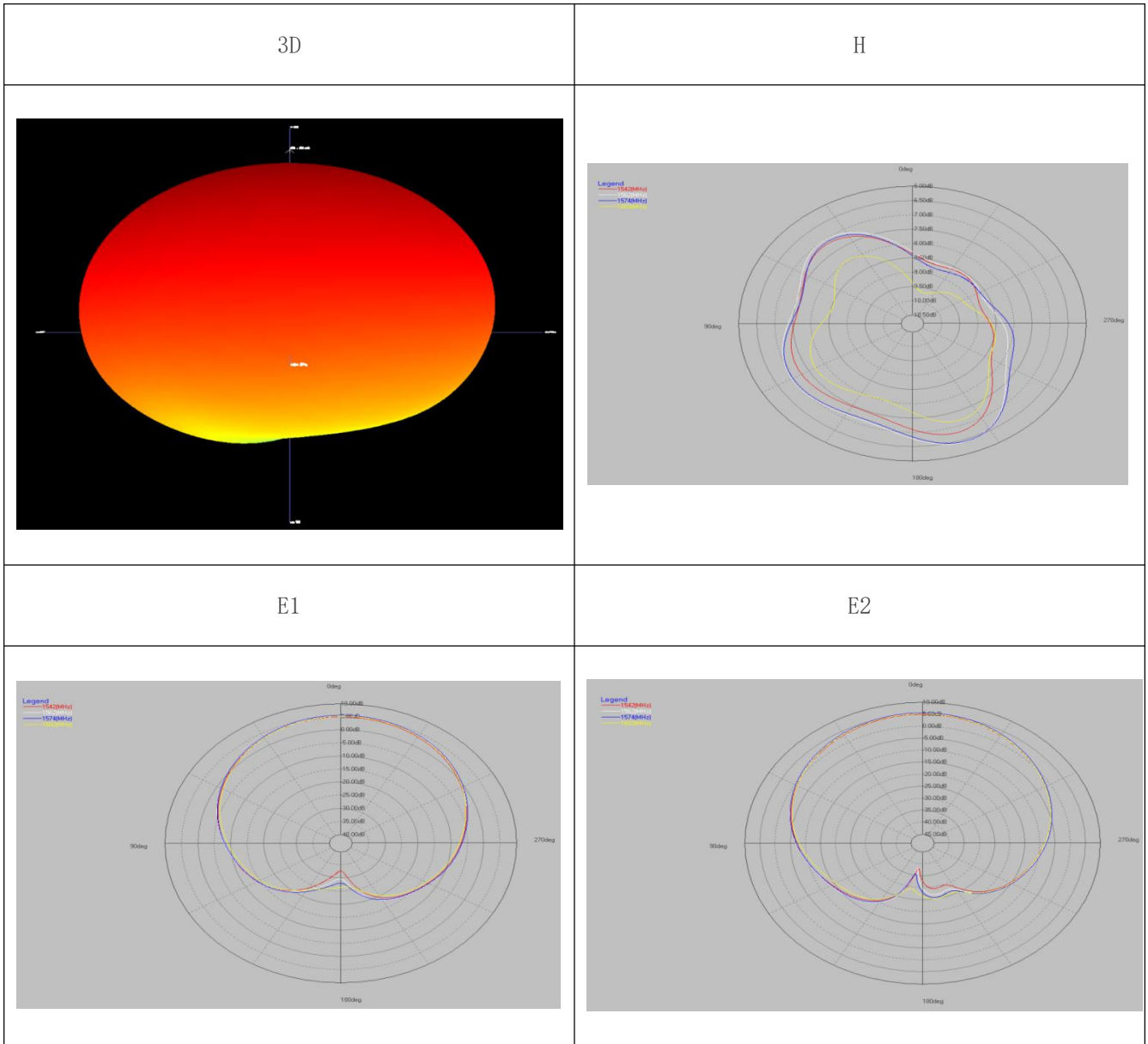

Product size drawing

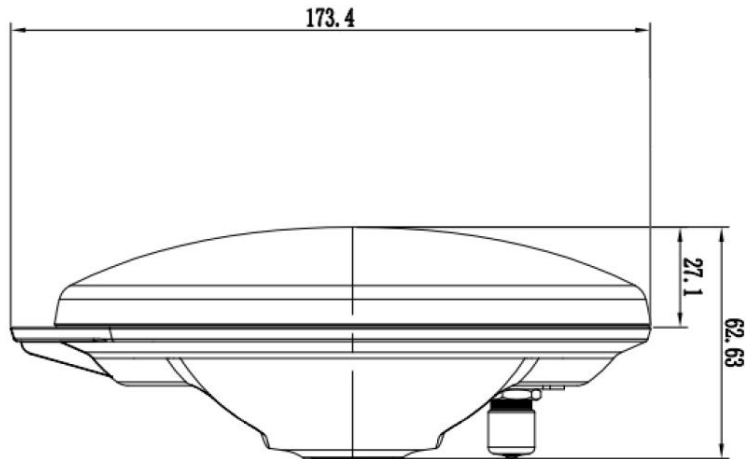

Frequency reference table

Global/Compass Navigation Satellite Systems(GNSS/CNSS)	5					2					6/3			6			1													
Frequency (MHz)	1164	1176	1188	1192	1207	1215	1219	1227	1239	1245	1252	1259	1266	1268	1278	1290	1535	1540	1545	1550	1558	1561	1563	1575	1587	1592	1602	1609	1616	2491
GPS(USA) L1,L2,L2C,L5	L5+/-12					L2/L2C+/-12										L6+/-5					L1+/-12									
Glonass(Russia) G1,G2											G2+/-7																	G1+/-7		
Galileo(Europian) L1,E1,E2,E5(E5a,E5b),E6	E5+/-15		E5a+/-12 E5b+/-12								E6+/-12						L6+/-5					E2	L1+/-17		E1					
Compass (Beidou 2,China)			B2+/-10								B3+/-10										B1+/-2									
Beidou 1 (China, Tx(LHCP)/Rx(RHCP))																													L	S
IRNSS (India)		L5+/-15																				L1+/-12							S+/-15	
OmniStar															O+/-14---->															